

# DanPumps S-WN Pumps

Vertical & horizontal wastewater pumps for dry pit installations





## DanPumps S-WN Pumps for Wastewater Applications

The dry installed DanPumps S-WN pumps are used for horizontal and vertical mounting. The pumps are compact in design to meet a wide range of service conditions. They are driven by an energy saving air-cooled IEC motor and connected to the piping with flanges on both suction and discharge sides.

### The Wastewater Program

With the range of pumps from the small S-WN1 to the large S-WN5, we cover the need from light industrial effluents to heavy duty wastewater jobs from both cities and industries. The flow rate varies from 68m<sup>3</sup>/h to 4000 m<sup>3</sup>/h with connections from DN80 to DN600. The S-WN pumps can be used in many different applications by adjusting the motor size and impeller type, the solution can easily be customized to comply with your requirements.

### Quality & Sustainability

We are committed to providing our customers with the best products at the highest quality standards in the industry. We provide complete testing facilities, capable of demonstrating pump performance and testing ancillary equipment to ensure smooth commissioning and startup procedures. Certified in accordance with ISO 9001:2015 and professional pump services - we can ensure the right solution that meets your specific needs:

- High pump efficiency
- Non-clogging impellers
- Life-long reliability





Fast lock latch bolt



Double Mechanical Cartridge Seal



B-tween impeller

### Unique Cartridge Seals & Easy Maintenance

Our unique double mechanical seals are installed in a user-friendly cartridge and make it possible to change the seal without using any special tools – it eliminates any risk of improper installation.

### Fast Lock Latch Bolt

Another unique feature for the DanPumps S-WN-line is the fast lock latch bolts which makes it easy to separate the pump from the motor. This feature is very popular among the service staff, as it reduces maintenance downtime considerably.

### Higher Efficiency with Adjustable Wear-ring.

The wear-ring reduces the hydraulic loss between the impeller and the wear-ring. With this feature, the wear-ring can regularly be adjusted to optimize the pump's efficiency.

### Premium Efficiency Motor

A Premium Efficiency motor as standard is the best way to reduce energy use as it improves efficiency without affecting the risk of blockage. An air-cooled IEC motor from 2,2 to 200 kW. Suitable for pumping wastewater and sewage from buildings and sites in domestic, commercial, industrial, and municipal areas.

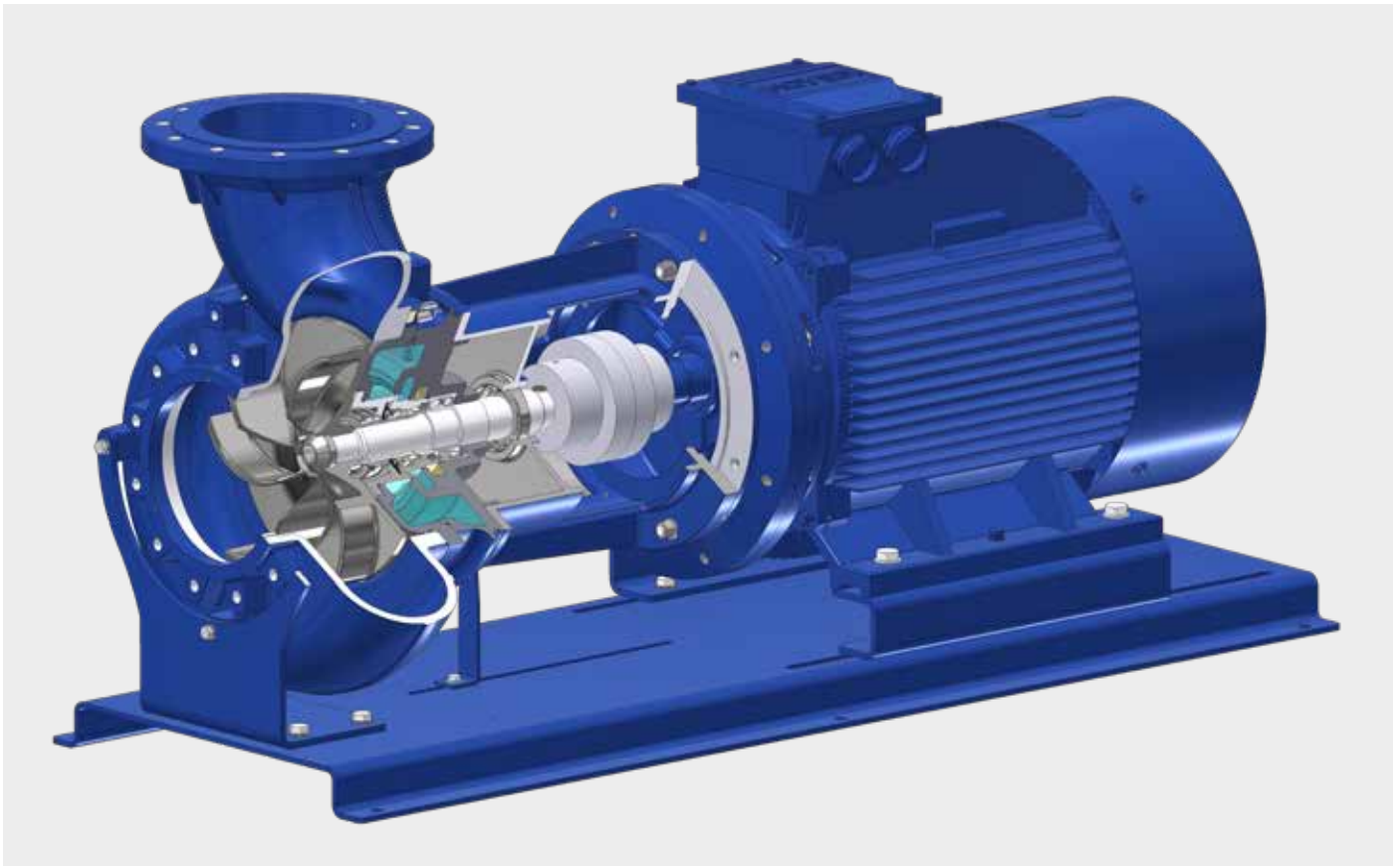

### High Efficiency with Unique Features

The design of the S-WN pump is a combination of high efficiency, intelligent design and practical features.

The efficiency of the pump is essential to reduce the running costs of the pump while at the same time reducing the carbon footprint, which is achieved by the design of the impeller and use of high-efficient motors – it gives you a user-friendly pump with a long-life cycle. Easy service will reduce maintenance costs, as it is simplified without the need to dismantle the entire pump.

The motor and hydraulics of the S-WN pump create a great pump reliability and high pump efficiency, which means:

- Reduced risk of overflows
- Reduced risk of interrupted service
- Reduced breakdown costs
- Reduced maintenance costs

### Features:

- All impellers fit in the same volute
- Cartridge seal
- High-efficient motors from well-known suppliers
- Easy maintenance
- Dry-installed, therefore no risk of contamination
- No need for entry into pump stations
- Easy removal of the motor without disconnecting the pump
- Good service access to pump suction side
- Built-in frequency converter up to 22 kW



## Horizontal or vertical pumping in dry installations

### Vertical:

- Requires a smaller service area than a horizontal pump
- Adjustable legs which make installation easier
- Top pull-out construction, easy access to the pump parts and easy removal of the motor
- Easy disassembly when making service by crain

### Horizontal:

- Easy dry installation
- The pump is on a baseplate, where sliding makes service easy
- Pump parts are easily accessible
- Suitable for almost all indoor applications due to its low headroom requirements

## Wastewater collection process

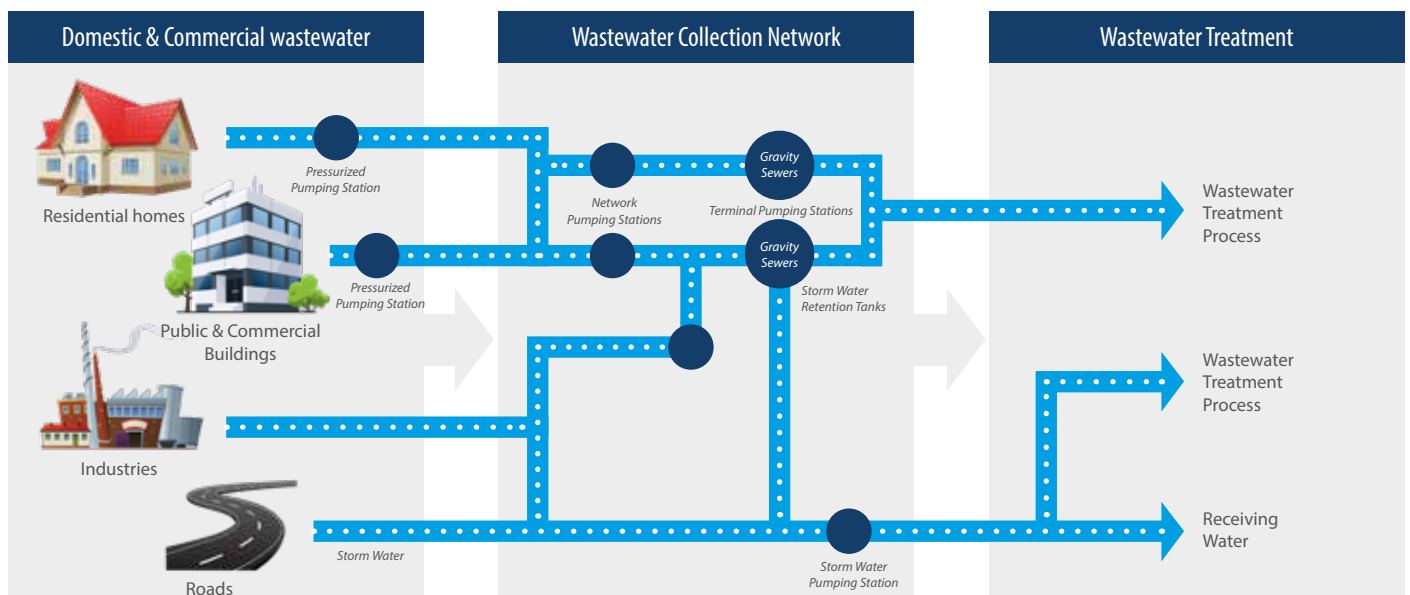

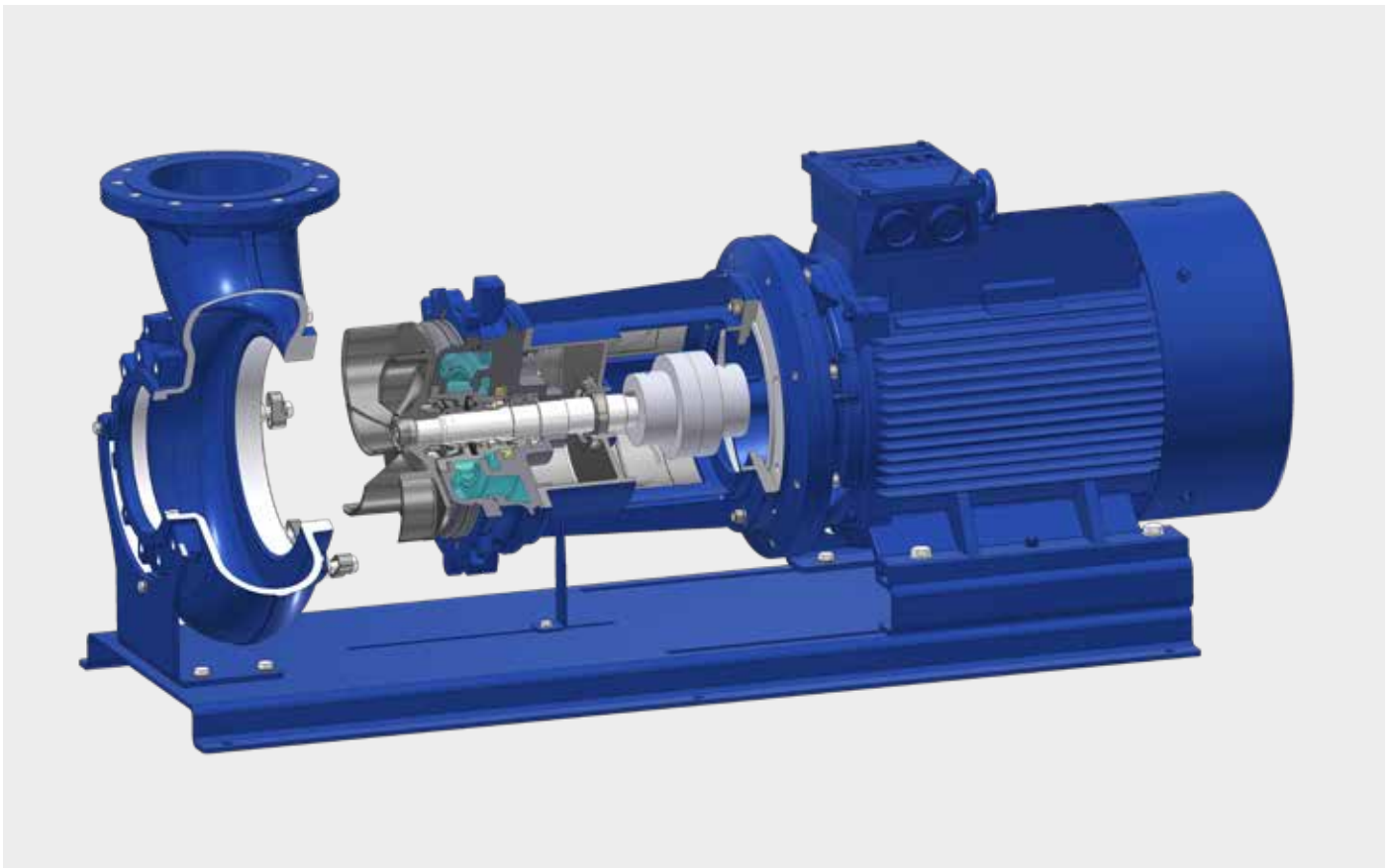

**Construction:**

- Horizontal version mounted on a steel base plate, vertical version mounted on adjustable legs
- Pull-out design allows easy removal of the motor without disconnecting the pump from the pipework
- Cartridge seal with double mechanical seals - the service time of changing the seal is reduced compared to a normal double mechanical seal
- Flexible coupling prolonging the lifetime of a pump
- Available in standard and explosion-proof versions in accordance with international standard ATEX operation is 75 °C
- Maximum ambient temperature: +75 °C
- Motor protection type: IP 55
- Insulation Class: F to 155 °C (Class H as an option)
- Connections from DN80 to DN600

**Main Benefits:**

- Dry-installed
- No risk of contamination
- Pull-out design
- IEC air-cooled motors IP55 (ATEX approved is optional)
- Flexible coupling for gentle operation of the pump

**Main Applications:**

- Clearwater
- Polluted water
- Heavily-polluted sewage containing solids, fecal slurry and sludge

# S-WN Pumps Performance Curves

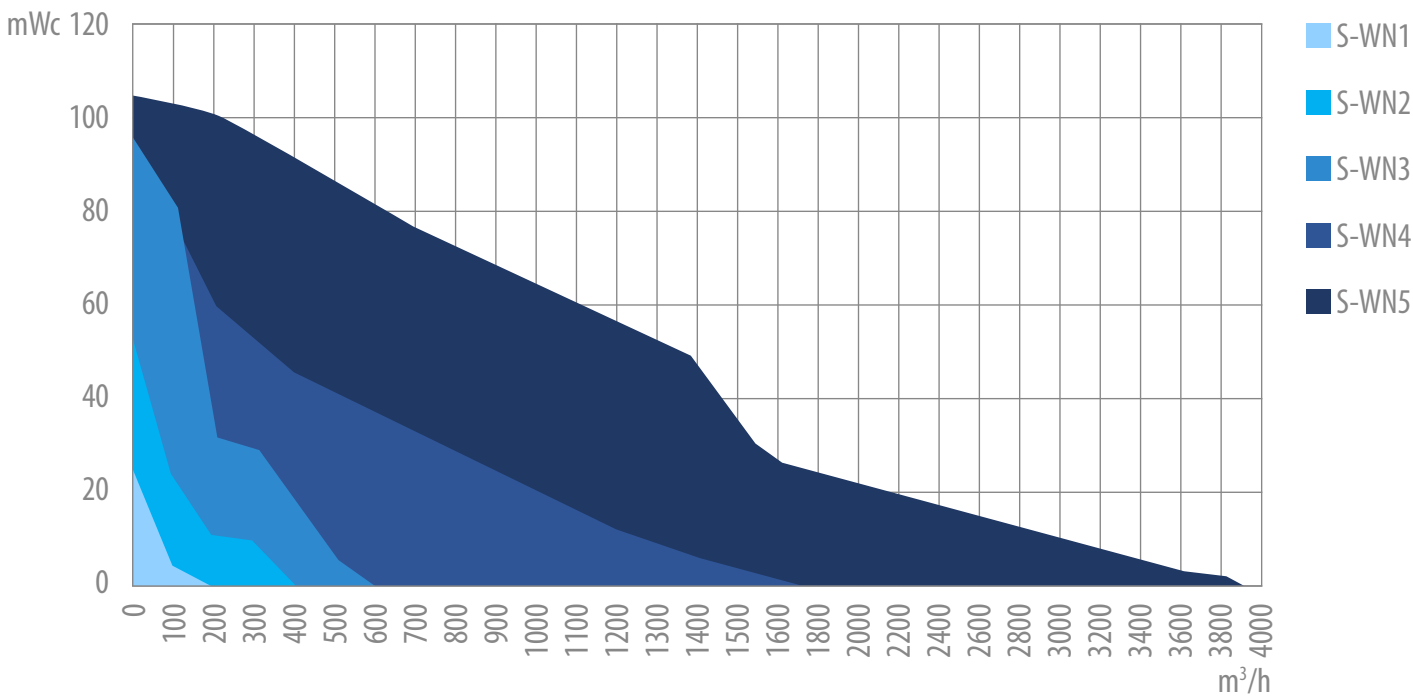

## Choose the Most Optimal Impeller:



- **One or two channel impeller**  
Higher efficiency (70-80%).  
Possibility of clogging.



- **B-tween impeller**  
Less efficient (60-75%).  
Lower possibility of clogging.



- **Vortex impeller**  
Less efficient (30-40%).  
Clogging free due to free passage, therefore it is reliable.



Vortex impeller made of AISI 316 stainless steel.

## Materials

<b>Pump Housing, Base Elbow, Sealing Housing</b>	Grey Cast Iron GJL-250 (GG25) A-48 Class35
<b>Impeller (cast iron), adapter</b>	Ductile Cast Iron GJS-400-15 (GGG-40) A536 GR 65-45-15
<b>Stainless Impeller (option)</b>	Stainless Cast Steel W.Nr.1.4401 / AISI 316
<b>Shaft</b>	Stainless Steel W.Nr.1.4057 / AISI 431
<b>Seal Sleeve, Screws</b>	Stainless Steel W.Nr.1.4301 / AISI 304
<b>O-rings</b>	Nitrile/ NBR
<b>Oil</b>	Mobil DTE 24 Premium Hydraulic
<b>Mechanical Seal</b>	Media Side: SIC/SIC Cooling Side: SIC (Carbon)
<b>Motor</b>	Hoyer /IE3 / Class F Optional as class H

**Impeller are delivered in cast iron, stainless steel and duplex as an option**



## About SonFlow A/S

DanPumps A/S changed its company name to SonFlow A/S in 2019 and started manufacturing plate heat exchangers - it signalizes new investments and new missions as we want to focus on process technology, energy and the environment. SonFlow A/S works hard to ensure the philosophy of innovation and advancement by delivering best in quality products and good service.

We strive our best to safeguard the environmental processes and adapt modern friendly approaches in product design and production processes. DanPumps centrifugal pumps are still being marketed under the brand name DanPumps.



## Plate heat exchangers as a complementary product

SonFlow A/S offers plate heat exchangers as a complementary product to DanPumps centrifugal pumps, which opens new markets. The engineering team of SonFlow is developing new designs and customized process equipment's based on many years of experience.

We are ISO 9001 certified and provide plate heat exchangers and pumps to all industries - we are continually expanding and diversify the business responding with innovative high-quality products and services.

## Manufacture of plate heat exchangers and pumps

SonFlow A/S is specialized in manufacturing centrifugal pumps within all industries and plate heat exchangers to use in thermal processes.

SonFlow offers a broad range of products for different applications - you can rely on SonFlow specialists to take a professional approach to your specific challenge and solve difficult pumping and plate heat exchanger applications.



Aage Søndergaard Nielsen  
Founder & CEO

**Your local distributor:**  
**IB pompen**  
**Hoogeveenseweg 46**  
**7933 PG Pesse**  
**The Netherlands**  
**[www.ib-pompen.nl](http://www.ib-pompen.nl)**  
**+31(0)528241748**

**Contact person:**  
**Olaf Bierens**  
**+31(0)6 25536750**  
**[olaf@ib-pompen.nl](mailto:olaf@ib-pompen.nl)**